



COMPUTING

ENG499

CAPSTONE ICT PROJECT

FINAL REPORT

**Analysis of Received pseudorandom
Sequence Coded Signal**

Student Name: Zheng Wei
Student PI: Q0605628
Course: ENG499
Tutor Name: Dr Lu Liru

Abstract

The major challenges of wireless communication are multiple users scheme and information security. One particular topic for secured wireless communication is the Direct Sequence spread spectrum transmissions.

The Direct sequence spread spectrum transmissions were initially developed for military applications, but they are now widely used for secure communications, especially for code division multiple access (CDMA), or global positioning systems (GPS). Spread spectrum signals are useful for secure communication for several decades, because the receiver has to know the sequence used by the transmitter to recover the transmitter data. In general, DS-SS transmitters use a periodical pseudo-random sequence to modulate the baseband signal before transmission. A receiver that does not know the sequence cannot demodulate the signal.

This report summarizes the design and implementation of direct sequence spread spectrum communications model using pseudorandom sequence. The following technology will be used and discussed for this project: Direct sequence spread spectrum system; pseudorandom sequence in time and frequency domain; How to generate the pseudorandom sequence and so on. The main software technology that applied for simulation and model is MATLAB.

Acknowledgement

I would like to extend my sincere gratitude and appreciation to Doctor Lu Liru, my final year project tutor for her invaluable guidance, advices and support. Miss Lu has given me a lot of encouragement and suggestions along the way from the beginning till completion of this project.

Last but not least, my heart-felt gratitude goes to everyone who has assisted me directly or indirectly in this project.

TABLE OF CONTENT

	Page
Chapter 1. INTRODUCTION	6
1.1 Project Overview	6
1.2 Project Background and motivation	7
1.3 Project Objective	9
1.4 Project Planning & Management	9
Chapter 2. Literature Review	12
2.1 Spread Spectrum Communication System	12
2.2 Direct Sequence Spread Spectrum	14
2.2.1 Features	14
2.2.2 Transmission method for DSSS	15
2.2.3 Spread Spectrum Code Estimation by Genetic Algorithm	16
2.2.4 Spread Spectrum Code Estimation by Particle Swarm Algorithm	19
2.2.5 Benefits	21
2.3 Frequency Hopped Spread Spectrum	21
2.4 Matlab Software	23
Chapter 3. OVERVIEW OF DIRECT SEQUENCE SPREAD SPECTRUM COMMUNICATION SYSTEM	24
3.1 Direct-Sequence Spread Spectrum Systems	24

3.2	Signal Demodulation	27
3.3	Probability of Error	28
3.3.1	The Jamming Margin	29
3.4	Pseudorandom Sequence	29
3.4.1	Definition of pseudo random sequence	29
3.4.2	Pseudo-random number generators	30
3.4.3	Correlation properties of PN sequence	31
3.5	DS spread spectrum signal in two applications	32
3.5.1	Low-Detestability Signal Transmission	32
3.5.2	Code Division Multiple Access	33
3.6	Monte Carlo simulation method	34
Chapter 4.	Matlab Simulation Program	36
4.1	DS Spread Spectrum System for Monte Carlo simulation	36
4.2	Generate L=31 Gold sequence	40
Chapter 5.	CONCLUSION	43
	REFERENCES	44

CHAPTER 1 INTRODUCTION

1.1 Project Overview

In telecommunications, **direct-sequence spread spectrum (DSSS)** is a modulation technique. As with other spread spectrum technologies, the transmitted signal takes up more bandwidth than the information signal that is being modulated. The name 'spread spectrum' comes from the fact that the carrier signals occur over the full bandwidth (spectrum) of a device's transmitting frequency.

The Direct sequence spread spectrum transmitters use a periodical pseudo-random sequence to modulate the baseband signal before transmission. A receiver that does not know the sequence cannot demodulate the signal.

This paper has presented research involving blind algorithms for estimation of spread spectrum sequence and detection. The purpose of this research is to: (1) look for ways to improve the efficiency of these algorithms; (2) investigate the real-time constraints of these algorithms; and (3) investigate the issues related to these algorithms.

In addition to the algorithm implementations, a Matlab data generation script will be created. This data generation script has several useful features including: (1) the ability to band limit the transmitter signal; (2) the ability to delay the transmitter signal by a non-integer multiple of the sampling period; and (3) the ability to quantize the receiver

output signal. This script takes commands from an ASCII command file and outputs generated data to files for use with the DSP target

1.2 Project Background and motivation

Over the past decades, there have been tremendous breakthroughs of various technologies including on communication and electronics field.

One interesting field that gone through enormous change is the wireless communication.

Fading and interference are the two fundamental aspects of wireless communication that make the problem challenging and interesting. These aspects are by and large not as significant in wire line communication. First is the phenomenon of *fading*: the time-variation of the channel strengths due to the small-scale effect of multipath fading, as well as larger scale effects such as path loss via distance attenuation and shadowing by obstacles.

Second, unlike in the wired world where each transmitter-receiver pair can often be thought of as an isolated point-to-point link, wireless users communicate over the air and there is significant *interference* between them in wireless communication. The interference can be between transmitters communicating with a common receiver, between signals from a single transmitter to multiple receivers.

The challenges of wireless communication have gone far including wireless communications used for secured applications. As an example is spread spectrum (SS) communications that is widely used for secure communications as well as multiple access and low probability of interception.

Initially the intended applications for spread spectrum is on military purposes but through the years there have several functions including Global Positioning System (GPS) which are mainly used to transmit at low power without jamming interference to other users or multi-path propagation.

Spread spectrum transmitters use a periodical pseudo-random sequence to modulate the baseband signal before transmission. A receiver, which does not know the sequence, cannot demodulate the signal. The spread spectrum techniques are useful for secure transmitter, because the receiver has to know the sequence used by the transmitter to recover the transmitter data.

Our purpose is to automatically determine the spreading sequence, whereas the receiver has no knowledge of the transmitter's code. Matlab simulations will examine the code estimation performance of the proposed algorithm

1.3 Project Objective

Direct sequence spread spectrum transmissions are mainly used to transmit at low power without interfered by jamming, to others user or to multi path propagation. The DS-SS transmitter use a periodical pseudo-random sequence to modulate the baseband signal before transmission, so the receiver has to know the sequence used by the transmitter to recover the data, because of this peculiarity, this technologies are useful for secure transmission.

The objective of this project is to automatically estimate the spreading sequence, and the receiver has no knowledge of the transmission data that are modulated by transmitter. The code estimation performance of the proposed algorithm can be examined by computer simulation.

Being equipped with knowledge from the courses taken prior to this final year project, such as key subjects like Engineering Mathematic I&II, Digital Communication I&II, and Digital Signal Processing and Signal and Systems can be a great aid for this project completion. Matlab will be use as the simulation software.

1.4 Project planning & management

The initial project design Gantt chart

- Review solution with Tutor.
- Identify resources of requires

Section 4

- Program design and development
- Update of documentation

Section 5

- Total integration of program
- Testing and Debugging.

Section 6

- Final Report
- Report submission

Section 7

- Individual presentation

CHAPTER 2 LITERATURE REVIEW

2.1 Spread Spectrum Communication Systems

Spread spectrum signals for digital communications were originally developed and used for military communications either (1) to provide resistance to hostile jamming, (2) to hide the signal by transmitting it at low power and, thus, making it difficult for an unintended listener to detect its presence in noise, or (3) to make it possible for multiple users to communicate through the same channel. Today, however, spread spectrum signals are being used to provide reliable communications in a variety of commercial applications, including mobile vehicular communications and interoffice wireless communications.

The basic elements of a spread spectrum digital communication system are illustrated in Figure 2.1a. We observe that the channel encoder and decoder and the modulator and demodulator are the basic elements of a conventional digital communication system. In addition to these elements, a spread spectrum system employs two identical pseudorandom sequence generators, one of which interfaces with the modulator at the transmitting end and the second of which interfaces with the demodulator at the receiving end. These two generators produce a pseudorandom or pseudo noise (PN) binary-valued sequence that is used to spread the transmitted signal in frequency at the transmitters to disperse the received signal at the demodulator.

Time synchronization of the PN sequence generated at the receiver with the PN sequence Contained in the received signal is required to properly dispread the received spreads spectrum signal. In a practical system, synchronization is established prior to the transmission of information by transmitting a fixed PN bit pattern that is designed so that the receiver will detect it with high probability in the presence of interference. After time synchronization of the PN sequence generators is established, the transmission of information commences

In the data mode, the communication system usually tracks the timing of the incoming Received signal and keeps the PN sequence generator in synchronism.

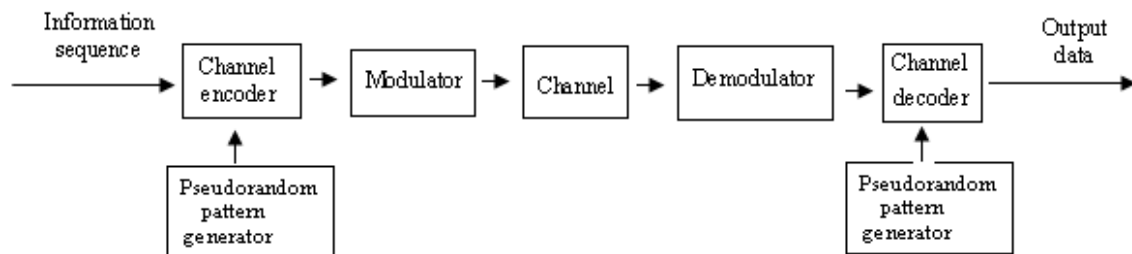

Figure 2.1a Model of spread spectrum digital communication system

There are two basic types of spread spectrum signals for digital communications namely direct sequence(DS) spread spectrum and frequency_hopped (FH) spread spectrum

2.2 Direct Sequence Spread Spectrum

In telecommunications, **direct-sequence spread spectrum (DSSS)** is a modulation technique. As with other spread spectrum technologies, the transmitted signal takes up more bandwidth than the information signal that is being modulated. The name 'spread spectrum' comes from the fact that the carrier signals occur over the full bandwidth (spectrum) of a device's transmitting frequency.

2.2.1 Features

1. It phase-modulates a sine wave pseudorandomly with a continuous string of pseudonoise (PN) code symbols called "chips", each of which has a much shorter duration than an information bit. That is, each information bit is modulated by a sequence of much faster chips. Therefore, the chip rate is much higher than the information signal bit rate.
2. It uses a signal structure in which the sequence of chips produced by the transmitter is known a priori by the receiver. The receiver can then use the same PN sequence to counteract the effect of the PN sequence on the received signal in order to reconstruct the information signal.

2.2.2 Transmission method for DSSS

Direct-sequence spread-spectrum transmissions multiply the data being transmitted by a "noise" signal. This noise signal is a pseudorandom sequence of 1 and -1 values, at a frequency much higher than that of the original signal, thereby spreading the energy of the original signal into a much wider band.

The resulting signal resembles white noise, like an audio recording of "static". However, this noise-like signal can be used to exactly reconstruct the original data at the receiving end, by multiplying it by the same pseudorandom sequence (because $1 \times 1 = 1$, and $-1 \times -1 = 1$). This process, known as "de-spreading", mathematically constitutes a correlation of the transmitted PN sequence with the PN sequence that the receiver believes the transmitter is using.

For de-spreading to work correctly, the transmit and receive sequences must be synchronized. This requires the receiver to synchronize its sequence with the transmitter's sequence via some sort of timing search process. However, this apparent drawback can be a significant benefit: if the sequences of multiple transmitters are synchronized with each other, the relative synchronizations the receiver must make between them can be used to determine relative timing, which, in turn, can be used to calculate the receiver's position if the transmitters' positions are known. This is the basis for many satellite navigation systems.

The resulting effect of enhancing signal to noise ratio on the channel is called *process gain*. This effect can be made larger by employing a longer PN sequence and more chips per bit, but physical devices used to generate the PN sequence impose practical limits on attainable processing gain.

If an undesired transmitter transmits on the same channel but with a different PN sequence (or no sequence at all), the de-spreading process results in no processing gain for that signal. This effect is the basis for the code division multiple access (CDMA) property of DSSS, which allows multiple transmitters to share the same channel within the limits of the cross-correlation properties of their PN sequences.

2.2.3 Spread Spectrum Code Estimation by Genetic Algorithm

DS-SS TECHNIQUE

In order to spread the signal power over a broadband channel, the direct sequence spread spectrum (DS-SS) technique consists in multiplying the information signal with a periodic pseudo-noise sequence.

Let us consider $b(t)$ the information signal

$$b(t) = \sum_{n=-\infty}^{\infty} b_n p(t - nT_b)$$

Where $b_n = \pm 1$ with equal probability and $p(t)$ is a rectangular pulse of duration T_b

Let's note y , the PN sequence of length k ,

$$y = y_0, y_1, \dots, y_{k-1}$$

The transmitter signal \hat{y}_n is the product of both waveforms. If we consider a direct sequence spread spectrum system without noise,

$$\hat{y}_n = b_n y$$

Assuming the receiver knows this sequence and can despread the signal using a correlator

$$\langle y, \hat{y}_n \rangle = \langle b_n y, y \rangle = b_n \langle y, y \rangle = b_n k$$

According to the properties of PN sequences, the data information is then recovered.

However it becomes more challenging when the receiver doesn't know exactly the code used by the transmitter.

Let us note \tilde{y} a sequence similar to y , but not exactly the same. Then using a correlator with \tilde{y} , we get

$$\langle \tilde{y}, \hat{y}_n \rangle = \langle b_n y, \tilde{y} \rangle = b_n \langle y, \tilde{y} \rangle$$

According to the properties of PN sequence, $\langle y, \tilde{y} \rangle$ is low and then we do not recover the data information.

The efficiency of any global positioning technique can be measured in terms of two properties the so-called explorative property and the exploitative property. Techniques that possess a high explorative property have a slower convergence rate and a higher computation complexity but they explore the entire space in order to locate the global

optimum. Hence accuracy is always guaranteed. Techniques such as the family of hill-climbing methods possess a high exploitative property, and hence they offer fast convergence to an optimum of a given subspace. However, this optimum may not be the global optimum of the entire solution space.

GAs constitute robust global search and optimization strategies that can strike an attractive balance between exploitation and exploration. These algorithms were introduced by Holland, and their principles are based on the concept of natural evolution. Specially, GAs use a population of candidate solutions initially distributed randomly over the entire solution space. Hence, GAs are highly explorative at the beginning. By evolving this population of candidate solution over successive iterations or generations, through probabilistic transition operations based on Darwinian survival of the fittest, the GA quickly identifies and exploits the subspaces, in which the global optimum may be located, while at the same time maintains the exploration of other parts of the solution space. Hence, while the optimum solution is not always located, the GA has a low probability of curtailing the exploration in suboptimal, rather than optimal solutions.

2.2.4 Spread Spectrum Code Estimation by Particle Swarm Algorithm

DS-SS TECHNIQUE

In order to spread the signal power over a broadband channel, the direct sequence spread spectrum (DS-SS) technique consists in multiplying the information signal with a periodic pseudo-noise sequence.

Let us consider $b(t)$ the information signal

$$b(t) = \sum_{n=-\infty}^{\infty} b_n p(t - nT_b)$$

Where $b_n = \pm 1$ with equal probability and $p(t)$ is a rectangular pulse of duration T_b

Let us note y , the PN sequence of length k ,

$$y = y_0, y_1, \dots, y_{k-1}$$

According to the properties of PN sequences, if we assume the receiver does not know this sequence, it cannot dispread the received signal. So we try to find some results, which can dispread the received signal, by using PSO algorithm.

The PSO algorithm, proposed by Kennedy and Eberhart has proved to be very effective in solving global optimization for multidimensional problems in static, noisy, and continuously changing environments. This introduced for the first time the GA

technique into spread spectrum code estimation and it uses PSO technique, which has

some properties, does not exist in GA technique. In reality, PSO and GA techniques are too similar and by making some changes to GA's algorithm, you have your PSO algorithm. At the beginning, the PSO algorithm randomly initializes a population (called swarm) of individuals (called particles). Each particle represents a single intersection of spreading code. The particles evaluate their position relative to a goal at every iteration. In each iteration, every particle adjusts its trajectory (by its velocity) toward its own previous best position, and toward the previous best position attained by any member of its topological neighborhood. If any particle's position is close enough to the goal function, it is considered as having found the global optimum and the recurrence is ended. Generally, there are two kinds of topological neighborhood structure, corresponding to the global version of PSO (GPSO), and local neighborhood structure, corresponding to the local version of PSO (LPSO). For the global neighborhood structure, the whole swarm is considered as the neighborhood, while for the local neighborhood structure, some smaller number of adjacent members in subswarm is taken as the neighborhood. In the global neighborhood structure, each particle's search is influenced by the best position found by any member of the entire population. In contrast, each particle in the local neighborhood structure is influenced only by parts of the adjacent members. Therefore, the LPSO has fewer opportunities to be trapped in suboptimum than the GPSO. Generally, the larger the number of particles adopted in PSO, the fewer the opportunities to be trapped in suboptimum, but the greater the time spent searching for the global optimum. In an earlier study there are 40 particles used in LPSO, which is a balance between the accuracy required

in searching for the global optimum and time consumed.

2.2.5 Benefits

There are some advantages to use Direct Sequence Spread Spectrum Communication Systems:

1. Resistance to intended or unintended jamming
2. Sharing of a single channel among multiple users
3. Reduced signal/background-noise level hampers interception (stealth)
4. Determination of relative timing between transmitter and receive

2.3 Frequency Hopped Spread Spectrum

In frequency hopped spread spectrum the available channel bandwidth W is subdivided into a large number of nonoverlapping frequency slots. In any signaling interval the transmitted signal occupies one or more of the available frequency slots. The selection of the frequency slot in each signal interval is made pseudorandomly according to the output from a PN generator.

A block diagram of the transmitter and receiver for a FH spread spectrum system is shown in Figure 2.3 The modulation is either binary or M-ary FEK. For example if binary FSK is employed, the modulator selects one of two frequencies, f_0 or f_1 corresponding to the transmission of a 0 for a 1. The resulting binary FSK signal is translated in frequency by an amount that is determined by the output sequence from

PN generator which is used to select a frequency f_c that is synthesized by the frequency synthesizer. This frequency-translated signal is transmitted over the channel. For example, by taking m bit from the PN generator, we may specify $2^m - 1$ possible carrier frequencies.

At the receiver, there is an identical PN sequence generator, synchronized with the received signal, which is used to control the output of the frequency synthesizer. Thus the pseudorandom frequency translation introduced at the transmitter is removed at the demodulator by mixing the synthesizer output with the received signal. The resultant signal is then demodulated by means of an FSK demodulator, a signal for maintaining synchronism of the PN sequence generator with the FH received signal is usually extracted from the received signal.

Although binary PSK modulation generally yields better performance than FSK, it is difficult to maintain phase coherence in the synthesis of the frequencies used in the hopping pattern and, also, in the propagation of the signal over the channel as the signal is hopped from one frequency to another over a wide bandwidth. Consequently, FSK modulation with non-coherent demodulation is usually employed in FH spread spectrum systems.

The frequency hopping rate, denoted as R_h , may be selected to be either equal to the symbol rate, lower than the symbol rate, or higher than the symbol rate. If R_h is equal to or lower than the symbol rate, the FH system is called a slow hopping system. If R_h

is higher than symbol rate, the FH system is called a fast hopping system.

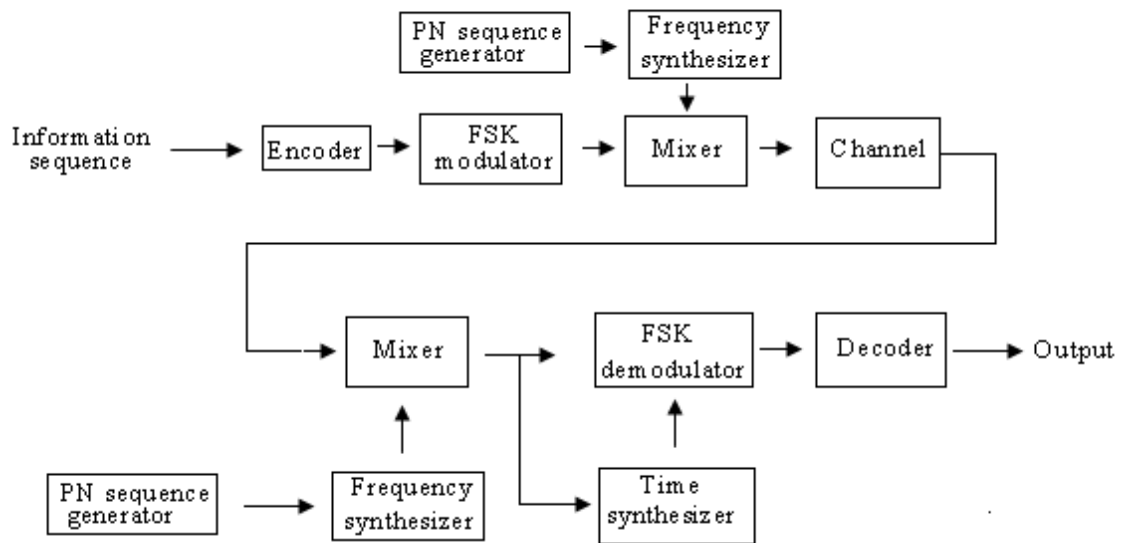

Figure 2.3 HF spread spectrum system

2.4 Matlab software

MATLAB® is a high-level technical computing language and interactive environment for algorithm development, data visualization, data analysis, and numeric computation.

The MATLAB is in a wide range of applications, including signal and image processing, communications, control design, test and measurement, financial modeling and analysis, and computational biology.

CHAPTER 3 OVERVIEW OF DIRECT SEQUENCE SPREAD SPECTRUM COMMUNICATION SYSTEM

This chapter describes the overall design of Direct Sequence Spread Spectrum Communication system. The concept of direct sequence spread spectrum communication system will be illustrated in the first section of this chapter. Then the following sections will be discussed with pseudo random sequence, PN number generator, and use the matlab to do the simulation.

3.1 Direct-Sequence Spread Spectrum Systems

The direct sequence spread spectrum considered in conjunction with spread spectrum namely PSK. PSK modulation is generally used with DS spread spectrum and is appropriate for application where phase coherence between the transmitted signal and the received signal can be maintained over a time interval that spans several symbol intervals.

The transmission of a binary information sequence by means of binary PSK. The information rate is R bits per second, and the bit interval is $T_b = 1/R$ seconds. The available channel bandwidth is B_c hertz, where $B_c \gg R$. At the modulator the bandwidth of the information signal is expanded to $W = B_c$ hertz by shifting the phase of the carrier pseudorandomly at a rate of W times per second according to the pattern

of the PN generator. The resulting modulated signal is called a direct-sequence spread spectrum signal.

The information-bearing baseband signal is denoted as $v(t)$ and is expressed as

$$v(t) = \sum_{n=-\infty}^{\infty} a_n g(t - nT_b)$$

Where $\{a_n = \pm 1, -\infty < n < \infty\}$ and $G(t)$ is a rectangular pulse of duration T_b , this signal is multiplied by the signal from PN sequence generator which may be expressed as

$$c(t) = \sum_{n=-\infty}^{\infty} c_n p(t - nT_c)$$

where $\{c_n\}$ represent the binary PN code sequence of ± 1 's and $p(t)$ is a rectangular pulse of duration T_c , as illustrated in Figure 3.1.1 This multiplication operation serves to spread the bandwidth of the information-bearing signal in to the wider bandwidth occupied by PN generator signal $c(t)$. The spectrum spreading is illustrated in Figure 3.1.2, which shows in simple terms using rectangular spectra, the convolution of the two spectra, the narrow spectrum corresponding to the information-bearing signal and the wide spectrum corresponding to the signal from the PN generator.

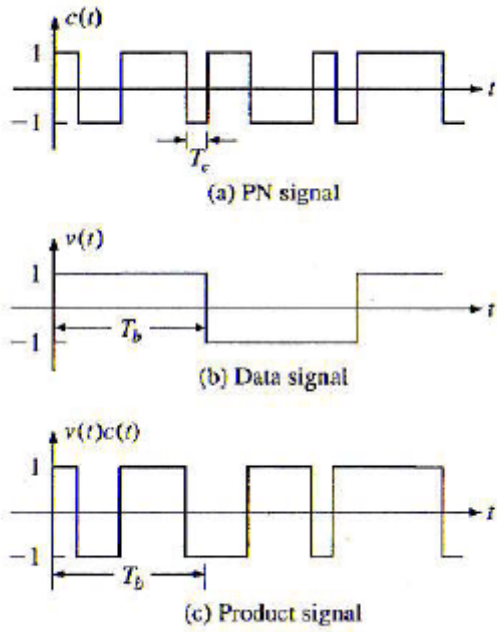

Figure 3.1.1 Generation of a DS spread spectrum signal

(a) PN signal (b) Data signal (c) Product Signal

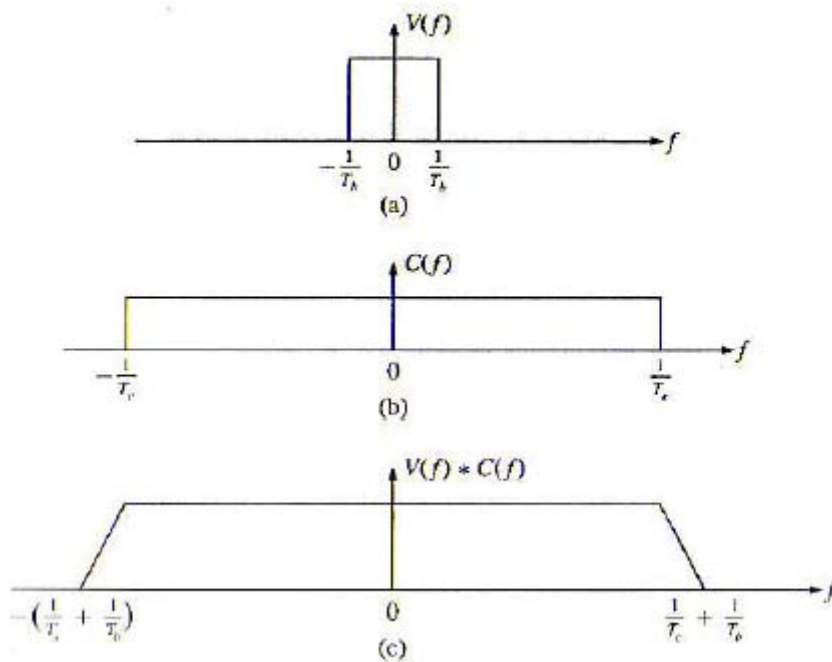

Figure 3.1.2 Convolution of spectra of the data signal and the PN code signal

3.2 Signal Demodulation

The demodulation of the signal is performed as illustrated in Figure 3.2. The received signal is first multiplied by a replica of the waveform $c(t)$ generated by the PN code sequence generator at the receiver, which is synchronized to the PN code in the received signal. This operation is called despreading, since the effect of multiplication by $c(t)$ at the receiver is undo the spreading operation at the transmitter. Thus we have

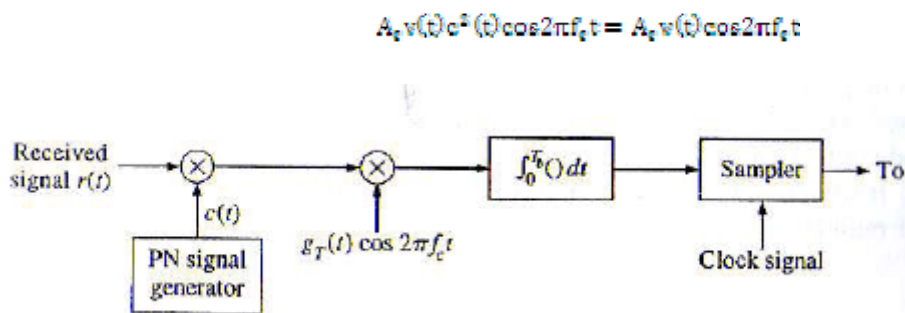

Figure 3.2 Demodulation of DS spread spectrum signal

. In summary PN code sequence is used at the transmitter to spread the information bearing signal into a wide bandwidth for transmission over the channel. By multiplying the received signal with a synchronized replica of the PN code signal, the desired signal is despread back to narrow bandwidth, whereas ant interference signals are spread over a wide bandwidth. The net effect is a reduction in the interference power by the factor W/R_t which is the processing gain of the spread spectrum system.

The PN code sequence is assumed to be known only to the intended receiver. Any

other receiver that does not have knowledge of the PN code sequence cannot demodulate the signal. Consequently, the use of a PN code sequence provides a degree of privacy that is not possible to achieve with conventional modulation. The primary cost for this security and performance gain against interference is an increase in channel bandwidth utilization and in the complexity of the communication system.

3.3 Probability of Error

In an AWGN channel, the probability of error for a DS spread spectrum system employing binary PSK is identical to the probability of error for conventional binary PSK

$$P_b = Q\left(\sqrt{\frac{2E_b}{N_0}}\right)$$

On the other hand, if the interference is the sin signal given by below equation with power P_j , the probability of error is

$$P_b = Q\left(\sqrt{\frac{2E_b}{N_0 + \frac{P_j}{W}}}\right) = Q\left(\sqrt{\frac{2E_b}{I_n}}\right)$$

Thus, the interference power is reduced by the factor of the spread spectrum signal bandwidth W . In this case, we have ignored the AWGN, which is assumed to be negligible. I.e., $N_0 \ll P_j/W$. If we account for the AWGN in the channel, the error probability is expressed as

$$P_b = Q\left(\sqrt{\frac{2E_b}{N_0 + I_0}}\right) = Q\left(\sqrt{\frac{2E_b}{N_0 + I_0}}\right)$$

3.3.1 The Jamming Margin

When the interference signal is a jamming signal, we may express $\frac{E_b}{I_0}$ as

$$\frac{E_b}{I_0} = \frac{P_s T_b}{P_j / W} = \frac{P_s / R}{P_j / W} = \frac{W / R}{P_j / P_s}$$

Now, suppose we specify a required E_b/I_0 to achieve a desired performance, then, using a logarithmic scale, we may express as

$$\left(\frac{P_s}{P_j}\right)_{\text{dB}} = \left(\frac{W}{R}\right)_{\text{dB}} - \left(\frac{E_b}{I_0}\right)_{\text{dB}}$$

The ratio $(P_j/P_s)_{\text{dB}}$ is called the jamming margin. This is the relative power advantage that a jammer may have without disrupting the communication system.

3.4 Pseudorandom Sequence

3.4.1 Definition of pseudo random sequence

A pseudorandom sequence is a code sequence of 1's and 0's whose autocorrelation has properties similar to those of white noise.

It is 'pseudo' because it is deterministic and after N elements it starts to repeat itself, unlike real random sequences, such as sequences generated by radioactive decay or by white noise. The PRBS is more general than the n -sequence, which is a special pseudo-random binary sequence of n bits generated as the output of a linear shift

register. An n -sequence always has a $1/2$ duty cycle and its number of elements $N = 2^k - 1$. PRBS's are used in telecommunication, encryption, simulation, correlation technique and time-of-flight spectroscopy.

3.4.2 Pseudo-random number generators

Pseudo-random number generators (PRNGs) are algorithms that can automatically create long runs (for example, millions of numbers long) with good random properties but eventually the sequence repeats exactly (or the memory usage grows without bound). One of the most common PRNG is the linear congruential generator, which uses the recurrence to generate numbers. The maximum number of numbers the formula can produce is the modulus, m . To avoid certain non-random properties of a single linear congruential generator, several such random number generators with slightly different values of the multiplier coefficient a are typically used in parallel, with a "master" random number generator that selects from among the several different generators. A simple pen-and-paper method for generating random numbers is the so-called middle square method suggested by John Von Neumann. While simple to implement, its output is of poor quality.

A PRNG can be started from an arbitrary starting state, using a seed state. It will always produce the same sequence thereafter when initialized with that state. The maximum length of the sequence before it begins to repeat is determined by the size of the state, measured in bits. However, since the length of the maximum period potentially doubles with each bit of 'state' added, it is easy to build PRNGs with periods long enough for many practical applications.

Most computer programming languages include functions or library routines that purport to be random number generators. They are often designed to provide a random byte or word, or a floating point number uniformly distributed between 0 and 1.

3.4.3 Correlation properties of PN sequence

The autocorrelation function is very important for periodic PN sequence, which is usually defined in terms of bipolar sequence $\{C_n\}$ as

$$R_c(m) = \sum_{n=0}^{L-1-m} C_n C_{n+m}, 0 \leq m \leq L-1$$

Where L is period of the sequence. Since the sequence $\{C_n\}$ is periodic with period L , the autocorrelation sequence $\{R_c(m)\}$ is also periodic with period L .

In some application the cross correlation properties of PN sequence are as important as autocorrelation properties. For example, Pseudo-random sequence with good correlation property and large linear span is widely used in code division multiple access (CDMA) communication systems and cryptology for reliable and secure information transmission. In this paper, sequences with long period, large complexity, balance statistics, and low cross-correlation property are constructed from the addition of m - sequences with pairwise-prime linear spans (AMPLS). Using m -sequences as building blocks, the proposed method proved to be an efficient and flexible approach

to construct long period pseudo-random sequences with desirable properties from short period sequences.

3.5 DS spread spectrum signal in two applications

In this section we briefly describe the use of DS spread spectrum signal in two applications. First, we consider an application in which the signal is transmitted at very low power, so that a listener would encounter great difficulty in trying to detect the presence of the signal. A second application is multiple-access radio communication.

3.5.1 Low-Detectability Signal Transmission

In this application the information-bearing signal is transmitted at a very low power level relative to the background channel noise and thermal noise that is generated in the front end of receiver. If the DS spread spectrum signal occupies a bandwidth W and the power spectral density of the additive noise is N_0 watts/hertz, the average noise power in the bandwidth W is $P_N = WN_0$

The average received signal power at the intended receiver is P_R . If we wish to hide the presence of the signal from receivers that are in the vicinity of the intended receiver, the signal is transmitted at a power level such that $P_R/P_N \ll 1$. The intended receiver can recover the weak information-bearing signal from the background noise with the aid of the processing gain and the coding gain. However, any other receiver that has

no knowledge of the PN code sequence is unable to take advantage of the processing gain and the coding gain. Consequently, the presence of the information-bearing signal is difficult to detect.

3.5.2 Code Division Multiple Access

The enhancement in performance obtained from a DS spread spectrum signal through the processing gain and the coding gain can be used to enable many DS spread spectrum signals to occupy the same channel bandwidth, provided that each signal has its own pseudorandom sequence, thus it is possible to have several users transmit message simultaneously over the same channel bandwidth. This type of digital communication, in which each transmitter/receiver user pair has its own distinct signature code for transmitting over a common channel bandwidth, is called code division multiple access.

In digital cellular communications, a base station transmits signal to N_u mobile receivers using N_u orthogonal PN sequence, one for each intended receiver, these N_u signals are perfectly synchronized at transmission, so that they arrive at each mobile receiver in synchronism. Consequently, due to the orthogonality of the N_u PN sequence, each intended receiver can demodulate its own signal without interference from the other transmitted signals that share the same bandwidth. However, this type

of synchronism cannot be maintained in the signals transmitted from the mobile transmitters to the base station. In the demodulation of each DS spread spectrum signal at the base station, the signals from the other simultaneous users of the channel appear as additive interference. Let us determine the number of simultaneous signals that can be accommodated in a CDMA system. We assume that all signals have identical average powers at the base station. In many practical system the received signal's power level from each user is monitored at the base station, and power control is exercised over all simultaneous users by use of a control channel that instructs the users on whether to increase or decrease their power levels. With such power control, if there are N_u simultaneous users, the desired signal-to-noise interference power ratio at a given receiver is

$$\frac{P_s}{P_N} = \frac{P_s}{(N_u - 1)P_s} = \frac{1}{N_u - 1}$$

From this relation we can determine the number of users that can be accommodated simultaneously.

3.6 Monte Carlo simulation method

Monte Carlo methods are a class of computational algorithms that rely on repeated random sampling to compute their results. Monte Carlo methods are often used when simulating physical and mathematical systems. Because of their reliance on repeated

computation and random or pseudo-random numbers, Monte Carlo methods are most suited to calculation by a computer. Monte Carlo methods tend to be used when it is unfeasible or impossible to compute an exact result with a deterministic algorithm

Monte Carlo simulation methods are especially useful in studying systems with a large number of coupled degrees of freedom, such as fluids, disordered materials, strongly coupled solids, and cellular structures (see cellular Potts model). More broadly, Monte Carlo methods are useful for modeling phenomena with significant uncertainty in inputs, such as the calculation of risk in business. These methods are also widely used in mathematics: a classic use is for the evaluation of definite integrals, particularly multidimensional integrals with complicated boundary conditions. It is a widely successful method in risk analysis when compared to alternative methods or human intuition. When Monte Carlo simulations have been applied in space exploration and oil exploration, actual observations of failures, cost overruns and schedule overruns are routinely better predicted by the simulations than by human intuition or alternative "soft" methods

CHAPTER 4 Matlab Simulation Program

4.1 DS Spread Spectrum System for Monte Carlo simulation

This section is to demonstrate the effectiveness of a DS spread spectrum signal in suppressing sinusoidal interference via Monte Carlo simulation.

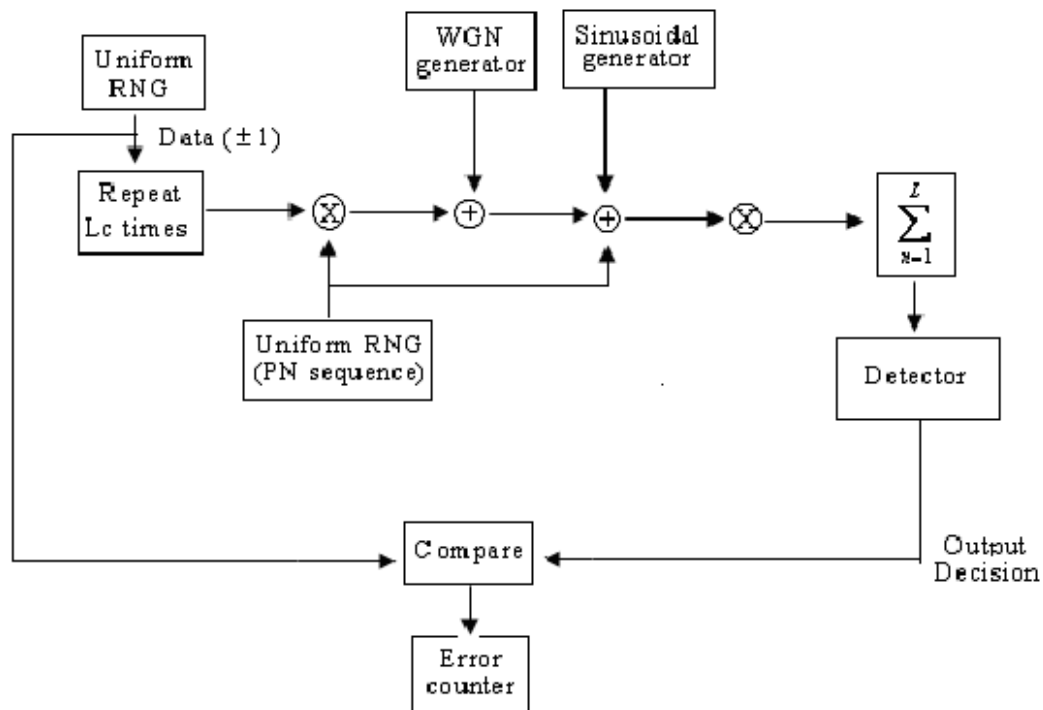

Model of DS spread spectrum system for Monte Carlo simulation

MATHLAB PROGRAM

echo on

```
Lc=20; % number of chips per bit
```

```
A1=3; % amplitude of the first sinusoidal interference
```

```
A2=7; % amplitude of the second sinusoidal interference
```

```
A3=12; % amplitude of the third sinusoidal interference
```

Student Name: Zheng Wei

Student No.: Q0605628

Course Code: ENG499

```

A4=0;      % fourth case: no interference

w0=1;      % frequency of the sinusoidal interference in radians

SNRindB=0:2:30

for i=1 :length(SNRindB),

% measured error rates

sml_d_err_prd1(i)=ss_Pe94(SNRindB(i), Lc, A1, w0);

sml_d_err_prd2(i)=ss_Pe94(SNRindB(i), Lc, A2, w0);

sml_d_err_prd3(i)=ss_Pe94(SNRindB(i), Lc, A3, w0);

end;

SNRindB4=0:1:8;

for i=1 :length(SNRindB),

% measured error rates when there is no interference

sml_d_err_prd4(i)=ss_Pe94(SNRindB(i), Lc, A4, w0);

end;

function [p] = ss_Pe94(snr_in_dB, Lc, A, w0)

% [p] = ss_Pe94(snr_in_dB, Lc, A, w0)

%          SS_PE92 finds the measured error rate. The function

%          that returns the measured probability of error for the given value of

%          the snr_in_dB, Lc, A and w0.

snr=10^(snr_in_dB/10);

sigma=1;      % noise standard deviation is fixed

```

```

Eb=2*sigma^2*snr; % signal level required to achieve the signal-to noise ratio

E_chip=Eb/Lc; % energy per chip

N=10000; % number of bit transmitted

% The generation of the data, noise, interference, decoding process, and error
% counting is performed all together in order to decrease the run time of the
% program. This is accomplished by avoiding very large sized vectors.

num_of_err=0;

for i=1 :N,

    % generate the next data bit

temp=rand;

if (temp<0.5),

    data=-1;

else

    data=1;

end;

% repeat it Lc times, i.e divide it into chips

for j=1 :Lc,

    repeated_data(j)=data;

end;

% PN sequence for the duration of the bit is generated next

for j=1 :Lc,

    temp=rand;

```

```

    if (temp<0.5),

        pn_seq(j)=-1;

    else

        pn_seq(j)=1;

    end;

end;

% the transmitted signal is

trans_sig=sqrt(E_chip)*repeated_data.*pn_seq;

% AWGN with variance sigma^2

noise=sgma*randn(1,Lc);

% interference

n=(i-1)*Lc+1:i*Lc;

interference=A*sin(w0*n);

% received signal

rec_sig=trans_sig+noise+interference;

% determine the decision variable from the received signal

temp=rec_sig.*pn_seq;

decision_variable=sum(temp);

% marking decision

if (decision_variable<0),

    decision=-1;

else

```

```

decision=1;

end;

% if it is an error, increment the error counter

if (decision~=data),

    nnum_of_err=num_of_err+1;

end;

end;

% then the measured error probability is

p=num_of_err/N

```

4.2 Generate L=31 Gold sequence

M-FILE

```

echo on

% first determine the maximal length shift register sequences

% we will take the initial shift register content as ?0001?

connections1=[1 0 1 0 0];

connections2=[1 1 1 0 1];

sequence1=ss_mlsrs(connections1);

sequence2=ss_mlsrs(connections2);

% cyclically shift the second sequence and add it to the first one

L=2^length(connections1)-1;

```

```

for shift_amount=0:L-1,

    temp=[sequence2(shift_amount+1:L) sequence2(1:shift_amount)];

    gold_seq(shift_amount+1,:)=(sequence1+temp) - floor((sequence1+temp)./2).*2;

end;

% find the max value of the cross correlation for these sequences

max_cross_corr=0;

for i=1:L-1,

    for j=i+1:L,

        % equivalent sequences

        c1=2*gold_seq(i,:)-1;

        c2=2*gold_seq(j,:)-1;

        for m=0:L-1,

            shifted_c2=[c2(m+1:L) c2(1:m)];

            corr=abs(sum(c1.*shifted_c2));

            if (corr>max_cross_corr),

                max_cross_corr=corr;

            end;

        end;

    end;

end;

end;

% note that max_cross_corr turns out to be 9 in this example.

```

```

function [seq]=ss_mlsrs(connections);

% [seq]=ss_mlsrs(connections)

m=length(connections);

L=2^m-1;          % length of the shift register sequence requested

registers=[zeros(1,m-1) 1];          % initial register contents

seq(1)=registers(m);          % first element of the sequence

for i=2:L,

    new_reg_cont(1)=connections(1)*seq(i-1);

    for j=2:m,

        new_reg_cont(j)=registers(j-1)+connections(j)*seq(i-1);

    end;

    registers=new_reg_cont;          % current register contents

    seq(i)=register(m);          % the next element of the sequence

end;

```

CHAPTER 5 CONCLUSION

The Analysis of Received Pseudorandom Sequence Coded Signal project was a very challenging experience for me as it requires us to build direct sequence spread spectrum communications model using pseudorandom sequence. I had learned a lot from this project at its different development stage, from principle of direct sequence spread spectrum system, definition of pseudo random sequence and how to generate it, test out the simulation of Matlab program.

For a part-time learning, the management between day time work and part-time course study can be a big challenge. This project had allowed me to learn about the project planning, independent researching on various materials either from Internet or books. It also had given me a very good chance to explore Java technology and web application design around in the current market. The skills development during this project cycle included

Reflecting back on the overall project management, I realized that this project has taught me a few useful lessons on how to manage time effectively. A Gantt chart and the project plan are most useful in this project. I had learnt that a Gantt chart should not be planned too detailed till the point of “day to day manning”. A Gantt chart should provide an overview of the tasks to be carried out against the project timeline.

Gantt chart and the project plan helped me to follow doing the targeted tasks in a more organized manner.

To conclude, the project is not able to achieve its main objectives. But I had enjoyed myself and learnt a lot acknowledge of Spread Spectrum Communication Systems from this project.

REFERENCES

1. http://en.wikipedia.org/wiki/Pseudo-random_binary_sequence<http://micromouse.cannock.ac.uk>
2. <http://en.wikipedia.org/wiki/DSSS>
3. <http://cbdd.wsu.edu/kewlcontent/cdoutput/tr502/page74.htm>
4. <http://www.springerlink.com/content/43wv6261v1h81u18/>
5. <http://acronyms.thefreedictionary.com/Pseudo-random+sequence>
6. http://en.wikipedia.org/wiki/PN_Sequences
7. <http://www.sensorsportal.com>
8. http://en.wikipedia.org/wiki/Pseudorandom_number_generator
9. <http://www.sciencedirect.com/science>
10. <http://www.springerlink.com/content/wv7q7068qw637n72/>

11. www.mathworks.com/
12. <http://www.math.utah.edu/lab/ms/matlab/matlab.html>
13. [HTTP://WWW.WASET.ORG/IJSP/V1/V1-1-8.PDF](http://www.waset.org/IJSP/V1/V1-1-8.PDF)
14. [HTTP://WWW.WASET.ORG/PWASET/V7/V7-40.PDF](http://www.waset.org/PWASET/V7/V7-40.PDF)
15. N. H. Anderson and D. M. Titterington Department of Statistics, University of Glasgow, G12 8QQ Glasgow, UK
16. D. Thomas Magill, Francis D. Natali, Gwyn P. Edwards, "Spread Spectrum Technology for Commercial Applications," *Proceeding of the IEEE*, vol. 82, pp. 572–584, April. 1994.
17. Raymond. L. Picholtz, Doland L. Schilling, Laurence B. Milstein, "Theory of Spread Spectrum Communications – A Tutorial," *IEEE Transactions on Communications*, vol. COM-30, pp. 855–884, May.1982.
18. John G. Proakis, *Digital communication*, Third Edition, Mac Graw Hill International Editions, 1995.
19. Paul H. Bardell, William H. McAnney, and Jacob Savir, "Built-In Test for VLSI: Pseudorandom Techniques", John Wiley & Sons, New York, 1987.
20. M. Yokoyama, "*Spread Spectrum Communication Systems*", Science and Technology Publishing Company, (1988)
21. Hatanaka, Y. Kawasaki, M. Takashima M. Wada, A. Shimodaira, "*Development of Spread Spectrum Transmission System for low voltage distribution line*".

Proceedings of the electronics information and system conf. LEE of Japan (1995)

